

# Receiver Gauge

Model No. **SS-3080 Series**



**SS-3081**



**SS-3084**

## Summary

This gauge is used for various kinds of receiver gauges which measure the amount, flux, differential pressure, pressure of the transfer system of pneumatic pressure and it uses bourdon pipes which have high viscosity and sensitiveness as an element.

### Safety Management

- Be sure to install a protecting device where exist abrupt change of pressure, vibration and pulsation.
- Do not give impact during the transportation, installation and usage.
- Be sure to install pressure gauge to be horizontal and vertical.

### Purpose of Use

- Various pneumatic pressure transmitter, amount of control valve (open, close)

### Production Specification

- ▶ Diameter
  - 100, 150 mm
- ▶ Accuracy
  - $\pm 1.0\%$  of Full Scale
- ▶ Scale Range
  - Linear Scale : 0 ~ 100%
  - Square Root Scale : 0 ~ 10 Root
- ▶ Working Pressure
  - Static pressure : 75% of Full Scale
  - Fluctuating pressure : 60% of Full Scale
- ▶ Working Temperature
  - Ambient : - 20 ~ 65 °C
  - Fluid : - 20 ~ 80 °C

### Product Specification

- |   |  |   |
|---|--|---|
| <ul style="list-style-type: none"> <li>+ Case                             <ul style="list-style-type: none"> <li>· STS 304</li> </ul> </li> <li>+ Cover                             <ul style="list-style-type: none"> <li>· STS 304</li> <li>· Slip-on-Fit</li> </ul> </li> <li>+ Connection                             <ul style="list-style-type: none"> <li>· STS 316</li> <li>· PF, PT ↔ 1/4(Female), 3/8, 1/2</li> </ul> </li> <li>+ Window                             <ul style="list-style-type: none"> <li>· Tempered safety glass,</li> <li>· Laminated safety glass</li> </ul> </li> </ul> | <ul style="list-style-type: none"> <li>+ Type                             <ul style="list-style-type: none"> <li>· A-Type (Rimless type)</li> <li>· B-Type (Surface type)</li> <li>· D-Type (Flush mounting type)</li> <li>· BD-Type (Panel attachment type)</li> </ul> </li> <li>+ Pointer                             <ul style="list-style-type: none"> <li>· Aluminum</li> <li>· Black coating</li> </ul> </li> <li>+ Dial                             <ul style="list-style-type: none"> <li>· Aluminum</li> <li>· White color coating</li> <li>· Black gradation and characters</li> </ul> </li> </ul> | <ul style="list-style-type: none"> <li>+ Element                             <ul style="list-style-type: none"> <li>· STS 304, STS 316</li> <li>· C type bourdon tube</li> </ul> </li> <li>+ Movement                             <ul style="list-style-type: none"> <li>· STS 304</li> </ul> </li> <li>+ Option                             <ul style="list-style-type: none"> <li>· Bracket</li> <li>· Accessories</li> </ul> </li> </ul> |
|---|--|---|

Pressure Gauge  
 Differential Pressure Gauge & Switch  
 Accessories of Pressure Gauge  
 Thermometer & Thermometer Switch  
 Thermocouple & R.T.D  
 Thermowell  
 Transmitter  
 Indicator etc.  
 Technical data

# Receiver Gauge

## Model No. SS-3080 Series

Model No. | SS-3081  
A Type (100, 150mm)

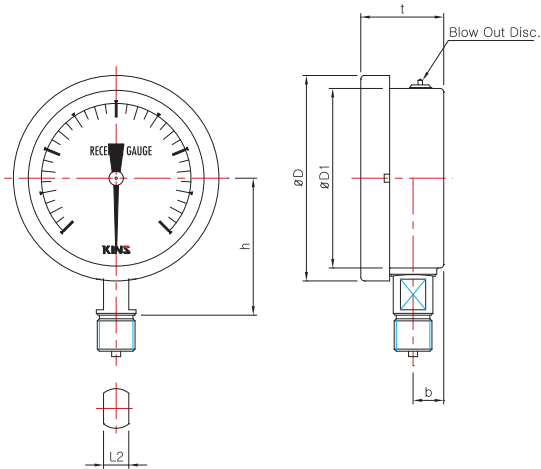

Model No. | SS-3083  
D Type (100, 150mm)

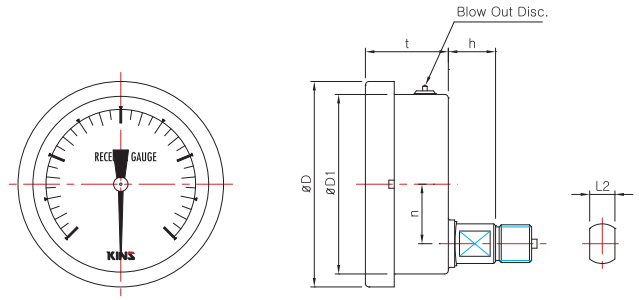

Model No. | SS-3082  
B Type (100, 150mm)

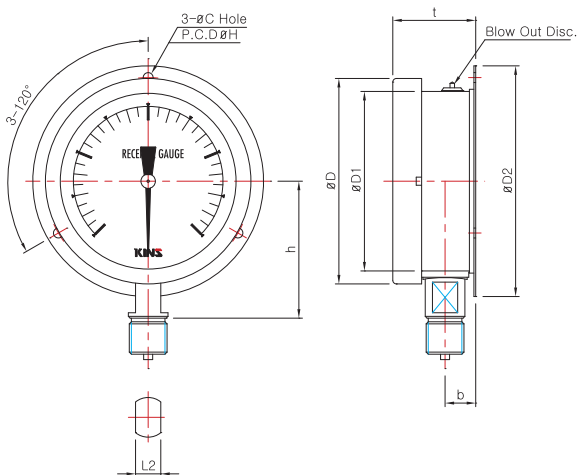

Model No. | SS-3084  
BD Type (100, 150mm)

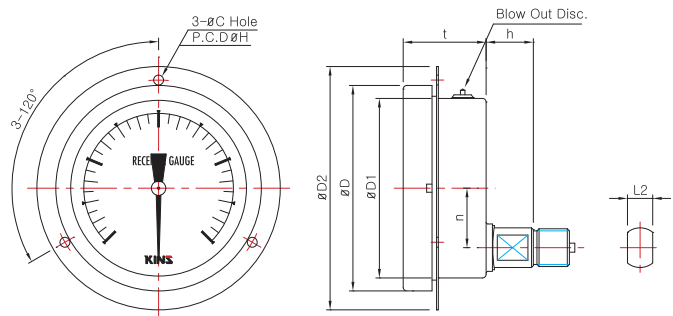

Pressure Gauge

Differential Pressure Gauge & Switch

Accessories of Pressure Gauge

Thermometer & Thermometer Switch

Thermocouple & R.T.D

Thermowell

Transmitter

Indicator etc.

Technical data

### Dimensions (mm)

	Model No.	Conn'n (d)	ØD	ØD1	ØD2	b	n	t	L2	h	ØC	ØH
100mm	SS-3081 & SS-3082	Female (1/4)	114	100	128	17	-	(46)	(17)	(76)	5.5	115
		NPT & PT, PF 1/4										
		NPT & PT, PF 3/8										
		NPT & PT, PF 1/2										
	SS-3083 & SS-3084	Female (1/4)	114	100	135	-	33	(46)	(17)	(26)	5.5	120
		NPT & PT, PF 1/4										
		NPT & PT, PF 3/8										
		NPT & PT, PF 1/2										
150mm	SS-3081 & SS-3082	Female (1/4)	168	152	188	17	-	(50)	(17)	(100)	5.5	174
		NPT & PT, PF 1/4										
		NPT & PT, PF 3/8										
		NPT & PT, PF 1/2										
	SS-3083 & SS-3084	Female (1/4)	168	152	188	-	33	(50)	(17)	(26)	5.5	174
		NPT & PT, PF 1/4										
		NPT & PT, PF 3/8										
		NPT & PT, PF 1/2										

\*( )The measurement in the blanket is approximate.

Pressure Gauge

Differential Pressure Gauge & Switch

Accessories of Pressure Gauge

Thermometer & Thermometer Switch

Thermocouple & R.T.D

Thermowell

Transmitter

Indicator etc.

Technical data